

GreaseShield®

The Grease Management Solution

The World's Best, and Only Eco Certified, Grease Recovery Unit



GS1850-CRM-4

APPLICATIONS



STEAM COMBI OVENS



CONVECTION OVENS



ROTISSERIE OVENS

ENVIRONMENTAL BENEFITS

- ✓ **Protects the Environment** - from pollution caused by Fats, Oils and Grease (FOGs).
- ✓ **Eco-Friendly** - GreaseShield® uses the least amount of energy in its class.
- ✓ **Protects the Drainage Network** - allowing drain lines to flow free from FOGs.
- ✓ **Harvests a source of renewable energy** - sustainable contribution to zero carbon emissions.
- ✓ **Compliance with local water companies and landlords** - preventing prosecution.

OPERATIONAL & COST SAVING BENEFITS

- ✓ **Eliminates recurring drain blockages** - caused by FOGs.
- ✓ **Eliminates frequent pumping costs and grease trap emptying.**
- ✓ **No requirement to purchase enzymes or bio additives.**
- ✓ **Automatic Grease Separation** - including emulsified animal fat.
- ✓ **No heating element** - so no risk of fire.
- ✓ **User friendliness** - No need for staff to access the internal of the machine and no more foul smelling grease traps.
- ✓ **No silt valve** - Preventing the discharge of FOGs to the drain line.



**Environmental
Products and Services Ltd**

Award Winning Technology

www.GreaseShield.com

HEAD OFFICE +44 (0) 28 3083 3081

sales@epas-ltd.com

GB OFFICE +44 (0) 161 477 5555

GreaseShield®

The Grease Management Solution

The World's Best, and Only Eco Certified, Grease Recovery Unit

GS1850-CRM-4- DAILY MAINTENANCE

No need to access the inside of the GreaseShield® - FOG's are automatically separated and extracted from your kitchen waste water.



Empty and clean the FOG collection container daily - The FOG's are collected in the external container.



Empty and clean the filter sleeve daily - Solids and food waste are collected in the filter sleeve.

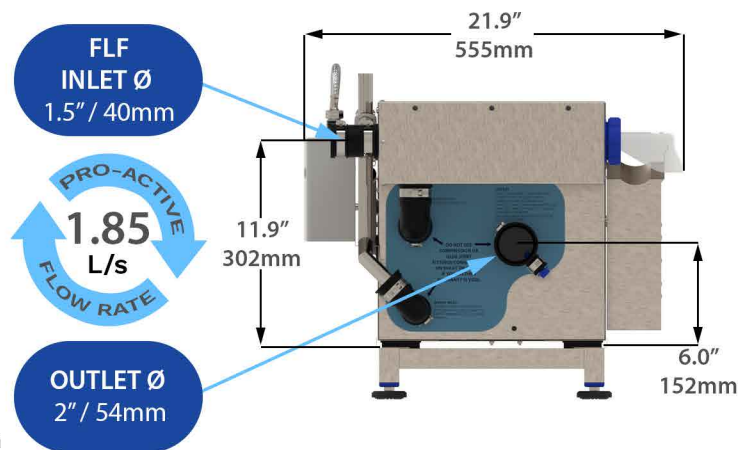
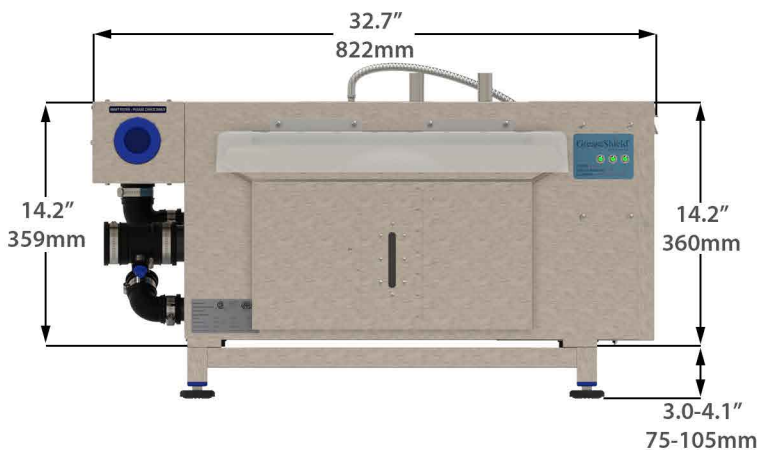

GREASESHIELD® SERVICES

- ✓ Compliance Support & Selection Proposals.
- ✓ Site Survey.
- ✓ Installation.
- ✓ Replacement Parts.
- ✓ Nationwide Support.
- ✓ Service & Maintenance.
- ✓ Technical Support & Design.



GREASESHIELD® PROTECTS



Environmental
Products and Services Ltd

Award Winning Technology

HEAD OFFICE +44 (0) 28 3083 3081
6, Shepherd's Way, Carnbane Industrial Estate,
Newry, County Down, N. Ireland, BT35 6EE

GB OFFICE +44 (0) 161 477 5555
Unit 6, Phoenix Court, Whitehill Industrial Estate, Hammond Avenue,
South Reddish, Stockport, Greater Manchester, SK4 1PQ