

Technical Specification - CombiPump to GS2000-PF



**PRE-FILTER
FOR SOLID WASTE
SEPARATION**

GreaseShield®

The Grease Management Solution

APPLICATIONS

- 6 to 20 Grid Convection Ovens
- Steam Combi Ovens
- Rotisserie Ovens

FLOW RATES & CERTIFICATION

- CombiPump Maximum Flow Rate - 2.0 L/sec (Depending on lift height and distance)
- GS2000 Pro-Active Flow Rate - 2.0 L/sec
- ASME Certification
- PDI Certification
- CSA Certification
- EN 1825 Certification

STANDARD FEATURES & FUNCTIONS

CombiPump

- Automatic Float Switch Activation.
- Low-Level Inlet Position, makes it compatible with most Commercial Ovens.
- Flexible Outlet hose and FlexiPlumb fittings provided for ease of installation.
- Transfers contaminated Effluent directly to the GreaseShield®.

GS2000

- Automatic FOG & solids removal
- Self cleaning
- Magnetic baffle for bioremediation
- PLC controlled
- Non restricted Vortex Flow Control device
- Reverse flow configuration
- Space Saver Running Trap & Sampling Point
- Globally certified award winning technology
- The only Green Certified grease trap in the world

Plumbing Connections

CombiPump Inlets	2"/50mm
CombiPump Outlet	1" ¼/32mm
CombiPump Overflow	2"/50mm
Pre-Filter Inlet	1" ½/40mm
GS2000 Outlet	2"/50mm
GS2000 Decant Outlet	¾"/18mm
Hot Water Solenoid	¾"/22mm

Electrical Ratings

	USA	UK,EU,AU,NZ
Voltage	110-120v	230v
CombiPump Current	3.6A	1.3A
GS2000 Frequency	60Hz	50Hz
GS2000 Current	0.98A	0.49A

Standard Operational Times

Days of Operation	7 Days a Week
Hours of Operation	07:00-02:30

Note: Operational times should be adjusted to suit the needs of the kitchen

Average Power Consumption

GS2000	15.8W Per Hour
--------	----------------

GREASESHIELD® CERTIFICATIONS & APPROVALS

- Global GreenTag LCA Rate Gold Certification
- PDI G101 (Plumbing & Drainage Institute)
- ASME A112.14.3 & A112.14.4 (American Society of Mechanical Engineers)
- NSF International (National Sanitation Foundation)
- CSA (Canadian Standards Association) - Grease Interceptors
- UL (Underwriters Laboratory)
- IAPMO (International Association of Plumbing and Mechanical Officials) Uniform Plumbing Code Certification Mark
- UKCA (UK Conformity Assessed)
- CE - Conformity with Health, Safety and Environmental Protection \ Standards with the European Economic Area (EEA)
- EN1825 (European Standard for Grease Separators)
- KIWA (ETA DK, Swedac & SINTEF) - Sweden, Norway and Finland. European Institution for Testing, Inspection and Certification
- SHASE-S 217:2016 (Japanese Grease Management Standard for Grease Interceptors)



**Environmental
Products and Services Ltd**

Award Winning Technology

www.GreaseShield.com

HEAD OFFICE +44 (0) 28 3083 3081

sales@epas-ltd.com

GB OFFICE +44 (0) 161 477 5555

V1 23/12/2021

Technical Specification - CombiPump to GS2000-PF

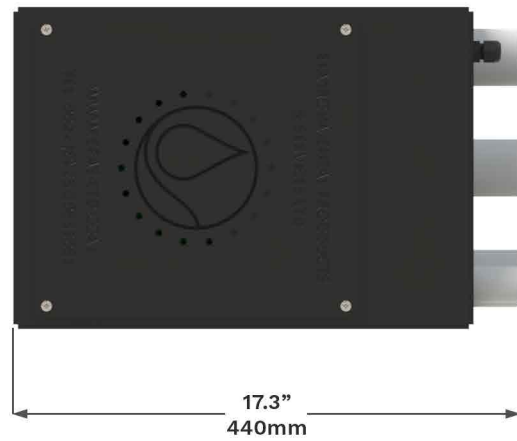
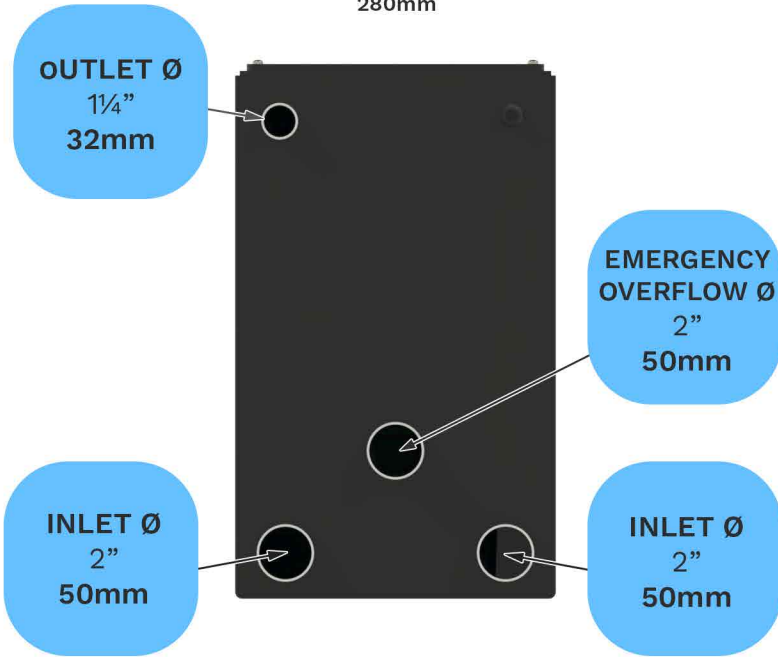
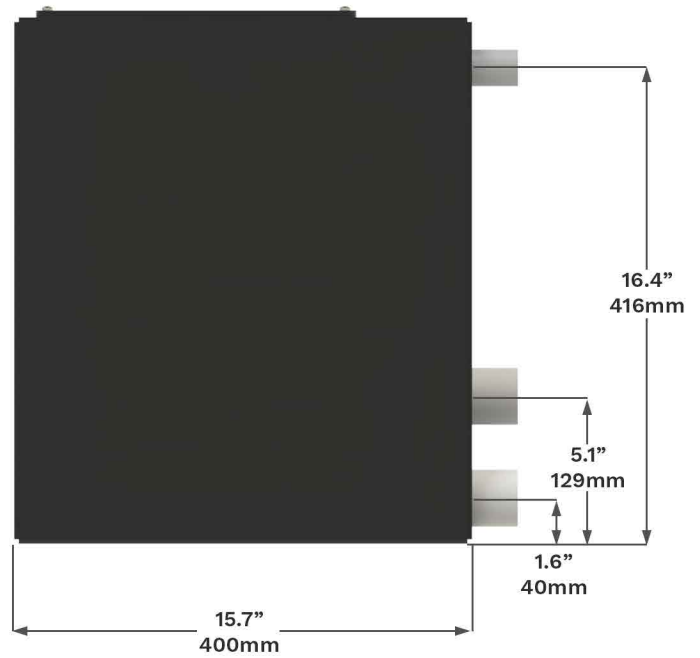
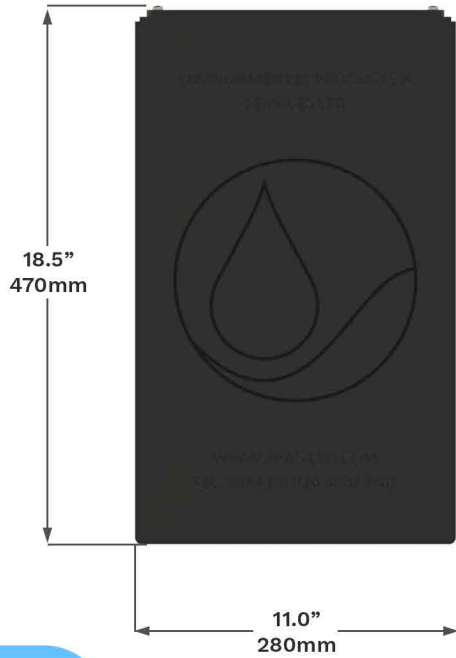

**Environmental
Products and Services Ltd**

Award Winning Technology

V1 23/12/2021

www.GreaseShield.com

HEAD OFFICE +44 (0) 28 3083 3081

sales@epas-ltd.com

GB OFFICE +44 (0) 161 477 5555

Technical Specification - CombiPump to GS2000-PF

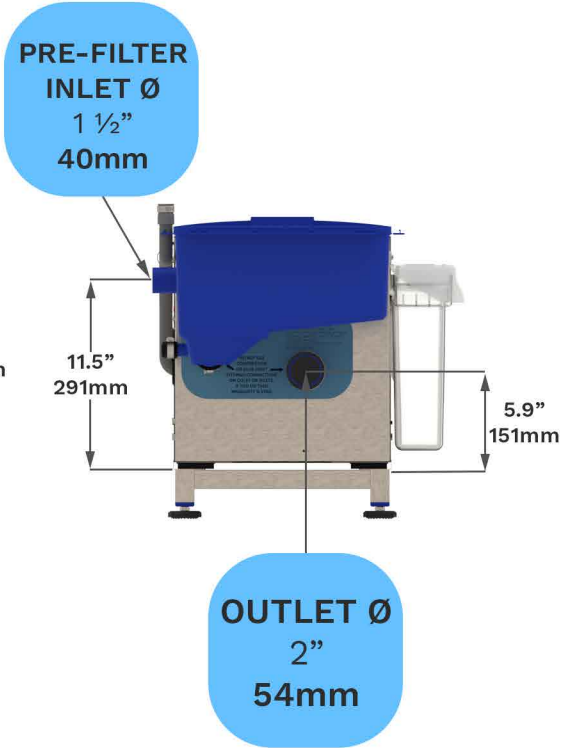
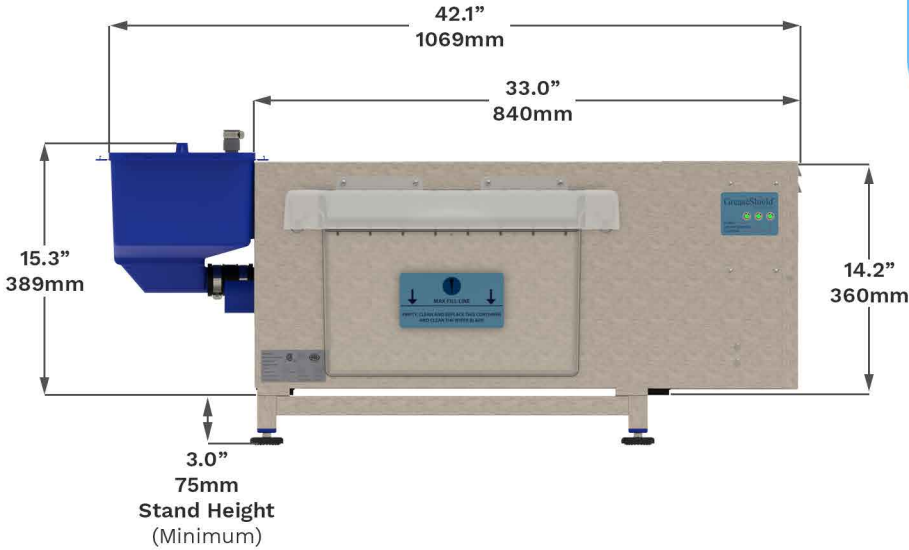

Environmental
Products and Services Ltd

Award Winning Technology

www.GreaseShield.com

HEAD OFFICE +44 (0) 28 3083 3081

sales@epas-ltd.com

GB OFFICE +44 (0) 161 477 5555

V1 23/12/2021